



**Assembly, Installation, Operation and
Maintenance Instructions
16KW 5TH WHEEL HITCH
Part # 33158 (Hitch Head and Yoke)
Part # 31567 (Cross Member)
Part # 31314 (2 Uprights)**

P/N: 33158



90-120 minutes

Dealer / Installer:	Provide a copy of these instructions to the end user of this product. These instructions provide important operating and safety information for proper usage of this product. Demonstrate the proper use of the product with the end user. Have the end user demonstrate that they understand the proper use of the product.
End User:	Read and follow all instructions included in this manual. Ask your Dealer / Installer for assistance if you do not understand the proper use of the product. Never remove any decals from the product.

**Part # 33158 (Hitch Head and Yoke)
will Be compatible with the
following kits:**

31666K (Shown in this manual)

31667K

32392K

33011K

33013K

33152K

33170K

**Please refer to owner's manual for
proper instructions.**

**Use with 4 bolt 31323 or 10 bolt
30686 base rails. Base Rails are
not included with this kit.**

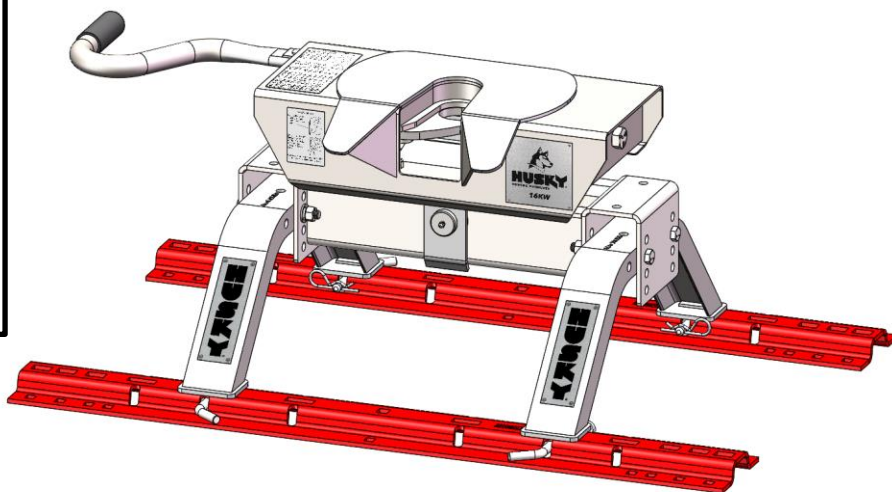

WARNING

Failure to follow all of these instructions may result in death or serious injury

NOTICE

Husky recommends to always drive the king pin into the hitch throat and not drop the king pin from above into the hitch head to avoid incorrect hook-ups. Please read Operating Instruction to understand how this important Safety Feature operates.

WARNING! Never exceed the towing capacity of the tow vehicle.

Introduction

- Safety is of paramount importance in both installation and use of the Husky 16K W 5th Wheel Hitch System. Observe all "Cautions" and "Notes" found in this manual, as well as common sense precautions to ensure the safety of yourself and others.
- Caution: The Husky 16K W 5th Wheel Hitch System is recommended for use only in truck beds 6 feet or longer. A Husky Heavy Duty Roller combined with a 16K W 5th Wheel Hitch is recommended for 6 foot short bed truck installations.
- For best results, it is recommended you have your Husky 16K W 5th Wheel Hitch System (33158, 31567, and 31314) professionally installed by a qualified technician.
- The Husky 16K W 5th Wheel Hitch System is designed to tow 5th Wheel Trailers with a total Gross Vehicle Weight Rating up to 16,000 lbs.
Do Not Exceed the Rated Capacity.
- King pin weight should never exceed 4,000 lbs.

Tools Listing

The following tools will be required for installation:

- (2) 7/16" wrenches/sockets
- (2) 3/4" wrenches/sockets
- 60mm wrench or pipe wrench
- Eye protection
- Gloves
- Torque wrench capable of 100 ft.-lbs. of torque

Package Contents

Unpacking: The Husky 16K W 5th Wheel Hitch Assembly (33158, 31567, and 31314) ships in three boxes as indicated below. The Husky 16K W 5th Wheel Hitch Assembly (33158, 31567, and 31314) does not include Base Rails. Inspect all parts for - damage & verify that all items listed are present.

33158 Box 1 Contains:

Hitch head (Qty 1)
Hitch Handle w\Grip (Qty 1)
Instructions

31567 Box 1 Contains:

Cross Member (Qty 1)
Hardware kit

31314 Box1 Contains:

Uprights (Qty 2)

Prior To Installation



Warnings

- * Check the Truck Payload and Trailer Weight as defined in Appendix A (Checking Truck & 5th Wheel Trailer Weight Rating). Never Overload Truck, Trailer or Hitch.
- * This Hitch requires Pre-Installed Base Rails which are bolted through the Bed of the Truck into brackets which in turn are fastened to the Truck Chassis. **DO NOT INSTALL HITCH BY FASTENING TO THE FLOOR OF THE PICKUP BOX.** The Pickup Box Floor is not strong enough to carry the loads imposed by the trailer
- * This 5th Wheel Hitch is rated for a **MAXIMUM** Pin Weight of 4,000 lbs. and a **MAXIMUM** Trailer GVW of 16,000 lbs. Exceeding Maximum ratings may result in death, serious injury or property damage.

The distance from the back of the truck cab to the center of the King Pin (Dim X) should be 4” greater than one-half the trailer width (Dim Y)

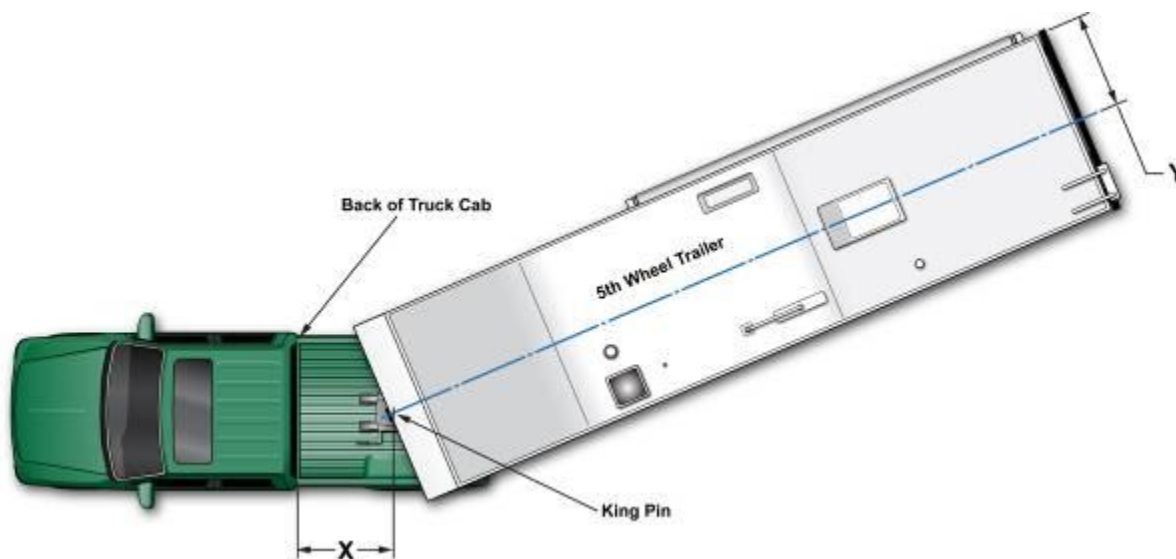

If towing with a short bed truck less than 8ft, Husky Towing recommend the use of a Husky Heavy Duty Roller for increased turning clearance at slow maneuvering speeds.

Assembly & Installation Procedures

1. Upright and Cross Beam Assembly

A) If using pre-existing base rails ensure that the center to center (fore and aft) distance is 22" and that there are two pairs of slots in the base rails that are 20-5/8" apart (side to side) Otherwise contact your local dealer for proper base rail selection and installation.

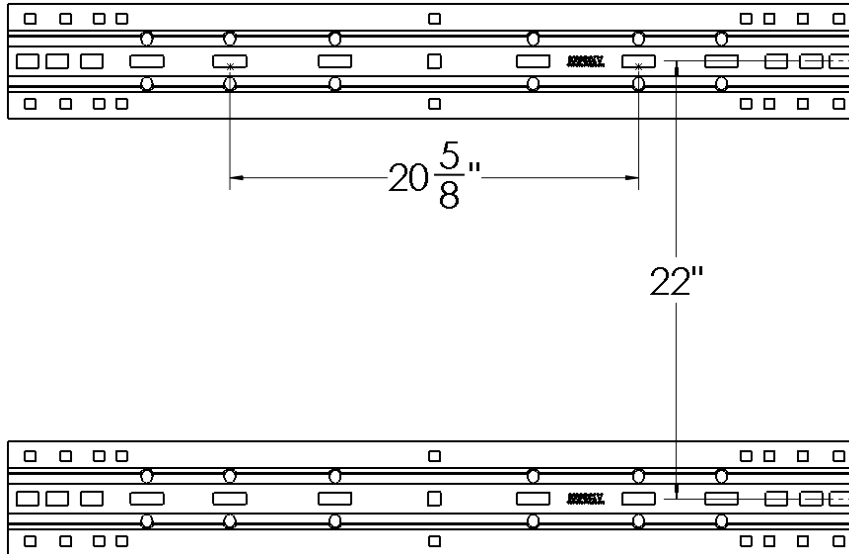

B) Place the uprights into the base rails with the decals facing the rear of the truck. Secure the uprights to the base rails using the 1/2 inch diameter clevis pins and secure using the large hairclips in the hardware bag.

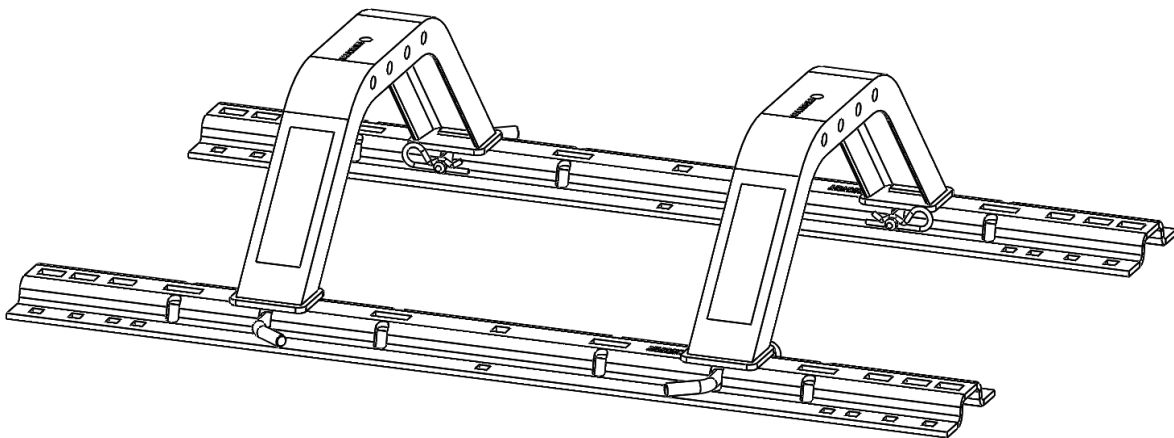

C) Install the Cross Beam.

NOTE: - The Cross Beam is adjustable in both the Vertical and the Fore & Aft directions. There are 4 vertical mounting positions in 1" increments. 2 Sets of holes in the Upright (item 17) provides 1" fore and aft movement from the center line of the Uprights.

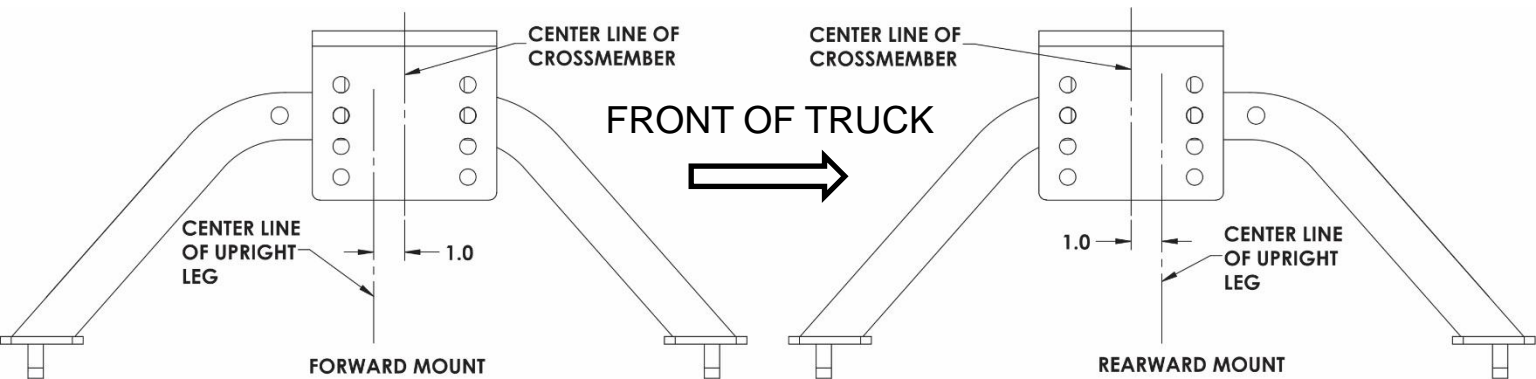

IMPORTANT:- The Center of the 5th Wheel Hitch should be positioned between 1" and 3" forward of the Center of the Rear Axle.

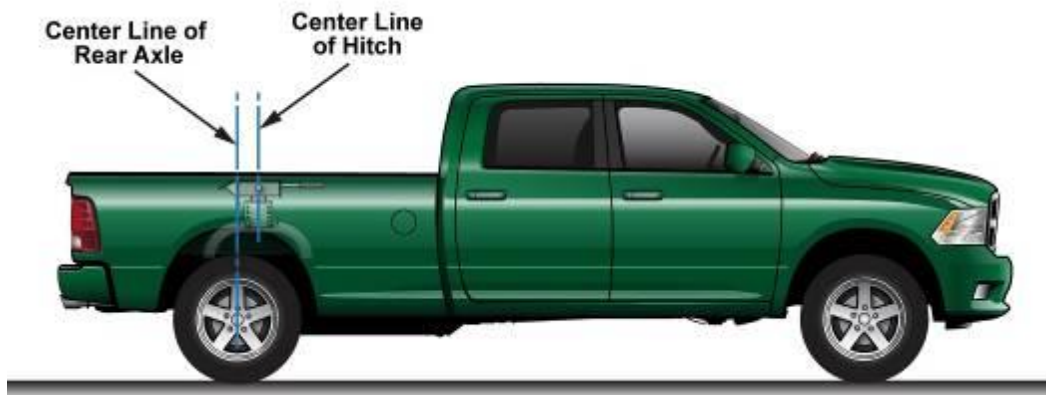

D) Find the center line of the rear axle and mark on the upright. Measure 1" forward of the mark and put a 2nd mark on the upright. Find a set of bolt holes in the upright and cross beam which positions the center of the cross beam as close as possible to this 2nd mark, while always keeping the center of the cross beam forward of the rear axle.

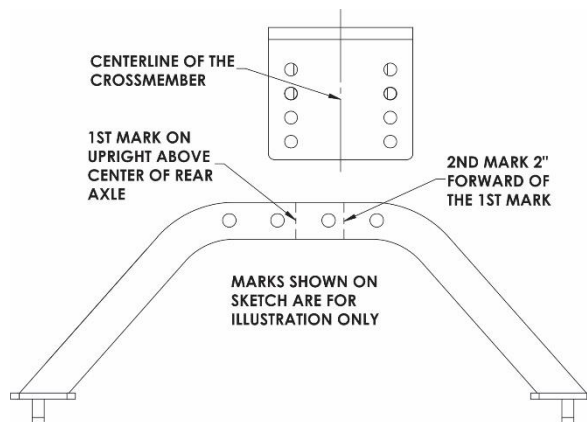

E) Once you've found the horizontal position for the cross beam, next find the vertical position for the cross beam.

NOTE: - If the Trailer is available for measuring follow the instructions in the section "Operating Instructions" sub section "Preparing For First Use". Otherwise put the Cross Beam in the highest position per instruction (F).

Use only the supplied bolts, nuts, and washers to install this kit. All nuts and bolts are Grade 5 unless specified otherwise.

F) Put the cross beam in the highest position using the pattern of holes on the end of the cross beam. Place a flat washer, lock nut, and nut on each bolt & finger tighten. Add shims as necessary to fill gaps. Snug down the four nuts using an "X" pattern. Torque the nuts to 75 ft-lbs. Note: Be sure that the Cross Beam straddles the uprights. **Do not over tighten**, as this will cause the uprights to fit improperly in the base rails.

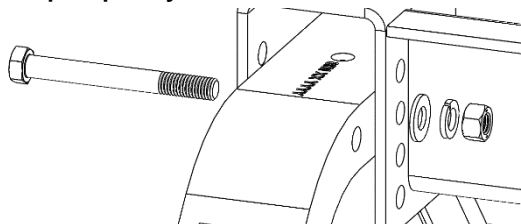

2. Head and Yoke Assembly

A) Install Head & Yoke with pivot pin and castle nut. Tighten the castle nut until all the fore and aft movement is eliminated in the pivot pin and in the head and yoke assembly. This may require 60mm wrench or pipe wrench. Continue to tighten the castle nut until the safety pin can be inserted. Close the clip on the locking clevis pin to secure the nut.

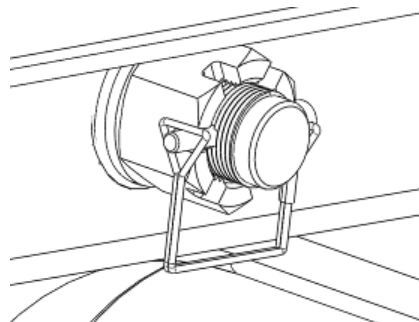

B) Using a grease gun, grease the Zerk fitting on the plate side of the pivot pin.

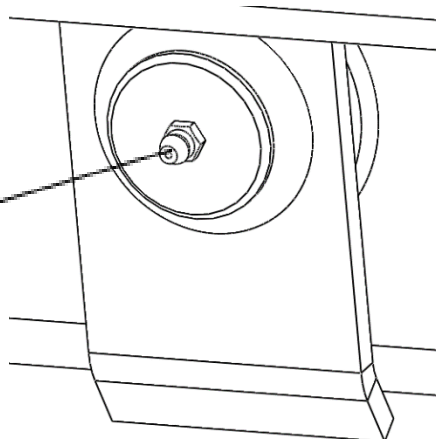

Zerk Fitting.

3. Handle Assembly

A) Attach the handle with the 3/8" Carriage Bolts, lock washers and nuts. Torque the nuts to 23 ft.-lbs. Ensure the padlock hasp points down as per the sketch.

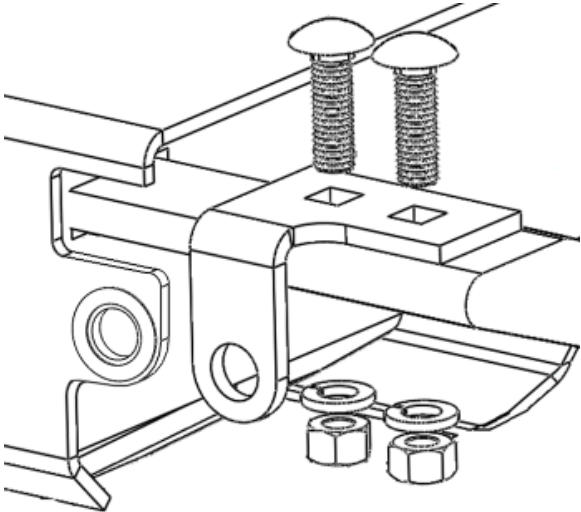

Understanding the Safety Features of your New HUSKY 5th Wheel.

This Husky 5th Wheel Hitch has new features which add to the safety and ease of operation. The most important feature to understand is that the Hitch will only fully close when the King Pin of the 5th Wheel Trailer is located correctly inside the Hitch. Before using this 5th Wheel Hitch for the first time, the Operator needs to understand the operation of the safety features of this Hitch. Pull the Handle fully out, and then let it slide back while pushing it gently forward towards the cab of the truck to miss the latch. The Hitch should partially close.

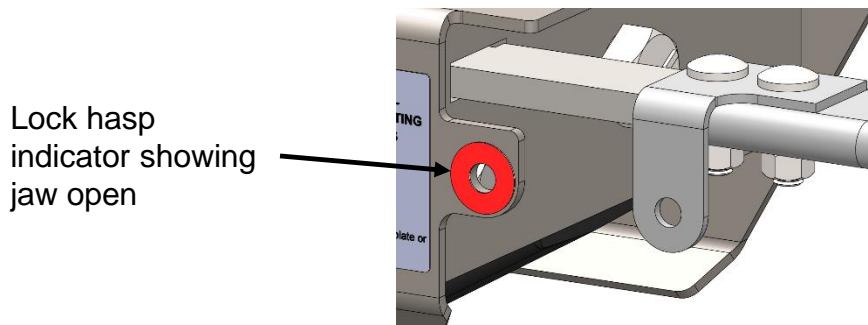

B) Looking at the front of the Hitch, the indicator should be as shown in the sketch above.

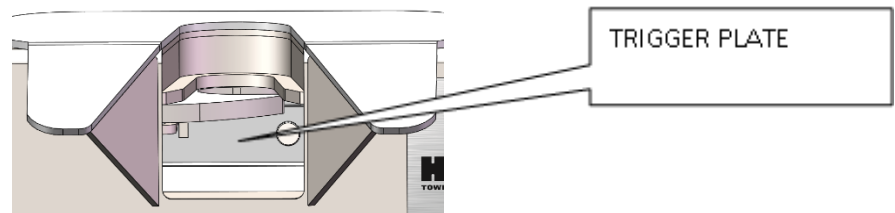

C) Using a Stick, (Keep fingers out of Jaw area) press on the Trigger Plate located underneath the Jaw. Pressing on the Trigger Plate will release the jaw mechanism and it will fully close. The Lock Hasp Indicator should now show that the Jaw is closed.

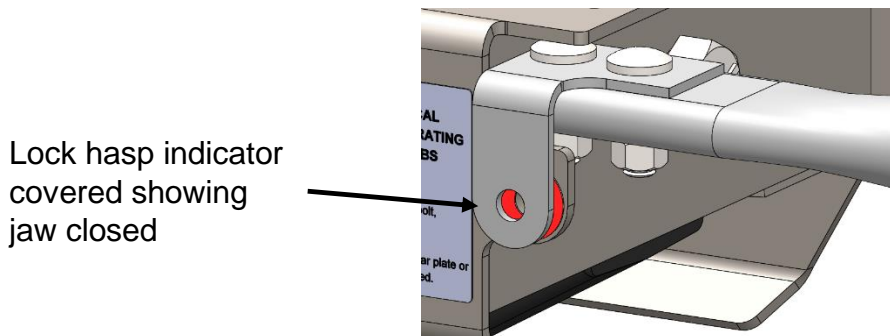

After the test, pull on the handle all the way out to reset the Latch Mechanism

⚠ WARNING
CLOSING THE HITCH BY TRIPPING THE TRIGGER PLATE SHOULD ONLY BE DONE AS A TEST. IN NORMAL OPERATION LEAVE THE HITCH OPEN UNLESS IT IS COUPLED TO A TRAILER.
ALWAYS PULL HANDLE OUT TO ENSURE HITCH IS OPEN BEFORE COUPLING THE TRAILER.

Operating Instructions

About Your Husky 16K W 5th Wheel Hitch

The Husky 16K W 5th Wheel Hitch System is designed to tow 5th Wheel Trailers with a Gross Vehicle Weight Rating up to 16,000 lbs. Do not exceed the rated GVWR of your vehicle as it will create an unsafe towing condition. It has a 4-way swivel head, its height is adjustable from 15.75 to 19.25 inches in 1-3/16 inch increments, and is removed from the bed of the truck by pulling 4 retaining pins.

Preparing For First Use

Your Husky 16K W 5th wheel system is now installed and you're anxious to be on your way down the road. You're almost there, but take a few minutes to ensure your hitch is set up properly for your particular truck/coach combination by following the steps below.

1. Verify that the cross member is set at the proper height to provide a minimum of 6" clearance between the bottom of the trailer nose and the top of the truck bedsides, and allows for a level-towing attitude of the 5th Wheel Trailer (See Figure 1 below).

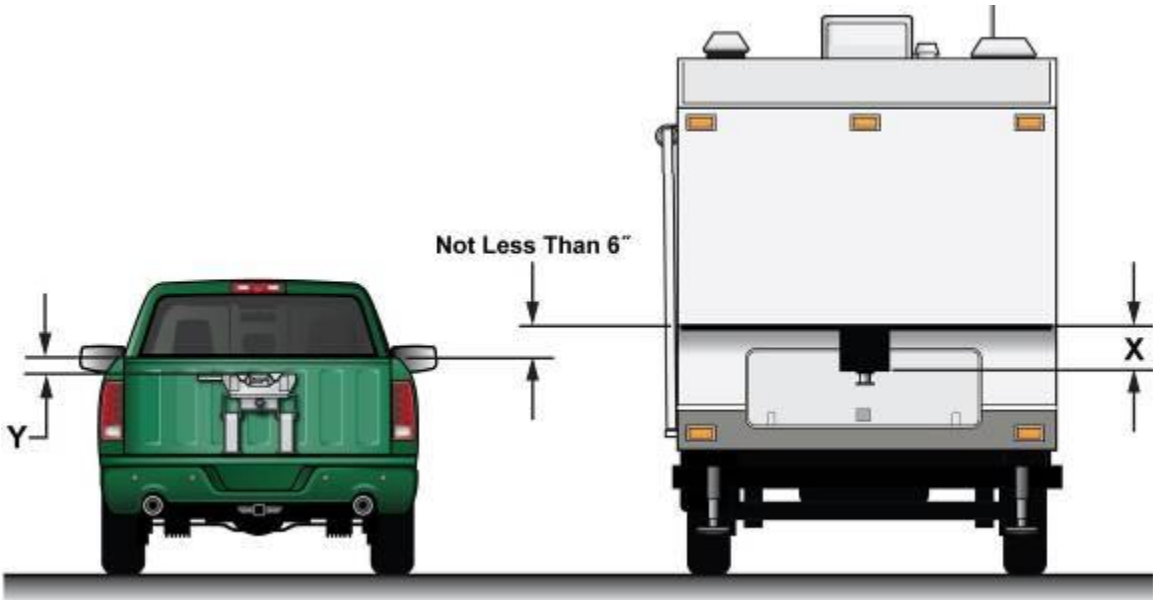

Figure 1

With top face of head level measure up to top of pickup box (dimension Y in Figure 1). On the trailer measure up from the face of the pin box to the underneath of the trailer (dimension X in Figure 1). Measurement X less measurement Y gives the amount of clearance between the top of the pickup box and the underneath of the trailer.

At a minimum this should be 6", if the trailer and tow vehicle are going off-road then this needs to be 8" to 10".



If this dimension is less than 6" DO NOT USE THIS TRAILER WITH THIS TOW VEHICLE. Severe damage may occur to both the pickup box and the trailer.

2. If necessary, adjust the cross member to the proper height, ensuring the fasteners are re-torqued to 75 ft. lbs.

Coupling Your Trailer

1. Ensure the 5th Wheel Trailer wheels are blocked front & rear & that the rear stabilizer jacks are fully retracted.
2. Also make sure the 5th Wheel Trailer landing leg feet are on a stable surface.
3. Pull handle fully out, then while pulling it to the rear of the truck let it slide back in until it catches on the latch.

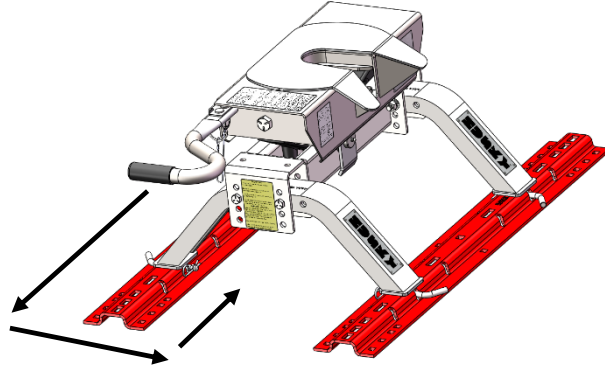

4. Check that the Orange indicator is not obscured by Lock Hasp. This shows the Hitch is unlocked.

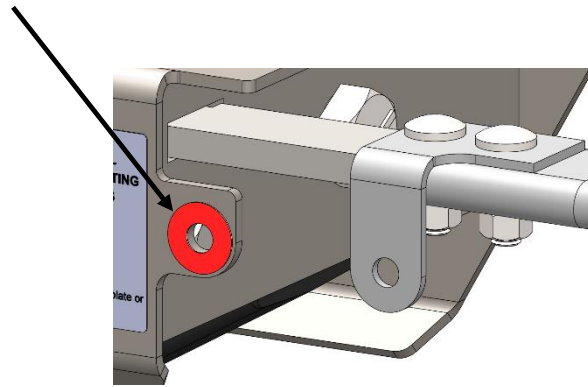

5. With hitch head level, set trailer king pin box $\frac{1}{2}$ " to 1" below hitch so trailer will ride up and onto hitch. Back Up the truck under the trailer so the king pin enters the hitch.

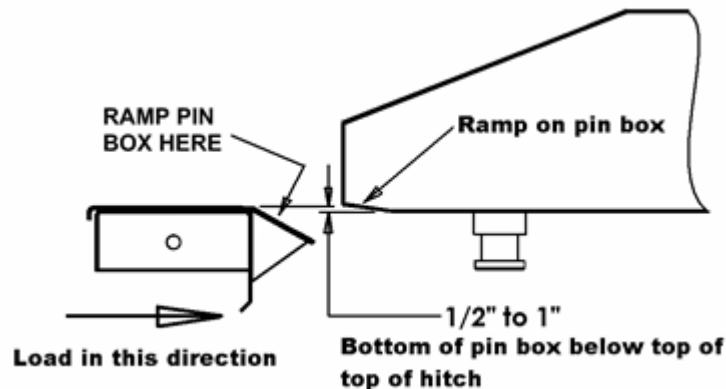

6. When the king pin is correctly seated in the hitch it will trip the latch. This will allow the jaw to close. The handle will move to the closed position and cover the indicator.

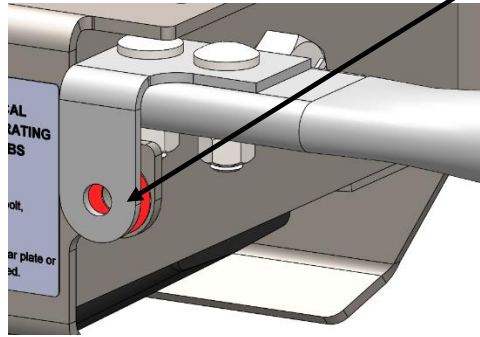

7. Use the supplied Locking Clevis Pin through the lock hasp to retain the hitch closed.

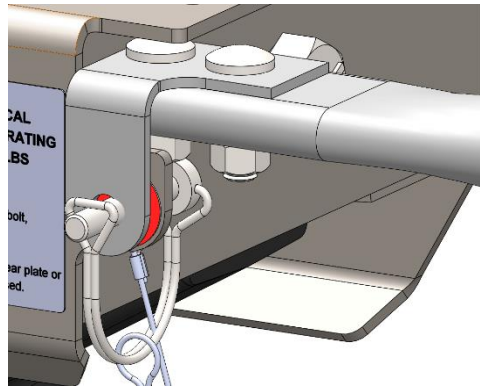

8. For additional security Husky Towing recommends using a Padlock instead of the Locking Clevis Pin to Securely Lock the handle closed.



WARNING

IF THE HANDLE WILL NOT CLOSE THEN THE KING PIN IS NOT POSITIONED CORRECTLY IN THE HITCH. UNCOUPLE THE TRAILER AND TRY AGAIN!!

Before Towing.

1. Connect and test power cables, attach emergency brake cable. With Trailer Landing Gear down, wheels chocked and the trailer brakes SET ON slowly pull forward to check security of king pin in hitch. Recheck connections and ensure Safety Pin or Padlock is through the lock hasp.
2. Remove the wheel chocks from the wheels of the 5th Wheel Trailer; Raise Trailer Landing Gear and double check that the hitch is properly attached to your tow vehicle.

Warning! Never back the tow vehicle under the trailer king pin and then lower the king pin into the hitch. This will result in high pinning and will result in hitch damage and possible vehicle damage, injury or death!

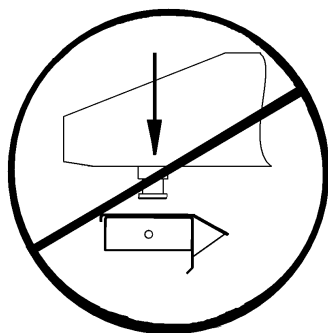

**NEVER LOWER THE TRAILER
ONTO THE HITCH**

**NEVER LOWER THE KING PIN INTO THE HITCH
USING THE TRAILER JACKS. THIS IS A VERY
DANGEROUS PRACTICE AND WILL RESULT IN THE
KING PIN SITTING ON TOP OF HITCH INSTEAD OF
INSIDE. THE TRAILER COULD THEN BECOME
DETACHED FROM THE TRUCK DURING TOWING
CAUSING SERIOUS DAMAGE AND POSSIBLY
INJURY OR DEATH.**

Uncoupling Your Trailer

1. Chock the front and rear wheels of your trailer.
2. If necessary, start your truck & back up against the kingpin to relieve pressure on the slide bar. Set the parking brake, put the transmission into park and then turn off your vehicle.
3. Extend the landing gear of the 5th Wheel Trailer until the weight of the 5th Wheel Trailer is just off of the 5th wheel plate of the hitch and on solid ground. Do not exceed 1/16" gap between the bottom plate of the king pin box and the top plate of the hitch
Caution: Raising the 5th Wheel Trailer too high while still connected can damage the hitch head as well as components of your 5th Wheel Trailer. Do not extend the rear stabilizers of the 5th Wheel Trailer prior to or during uncoupling.
4. Disconnect the electrical and breakaway connectors in accordance with your 5th Wheel Trailer owner's manual.

5. Pull handle fully out, then while pulling it to the rear of the truck let it slide back in until it catches on the latch.

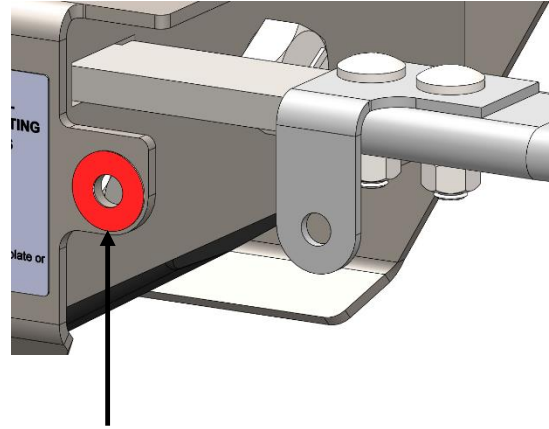
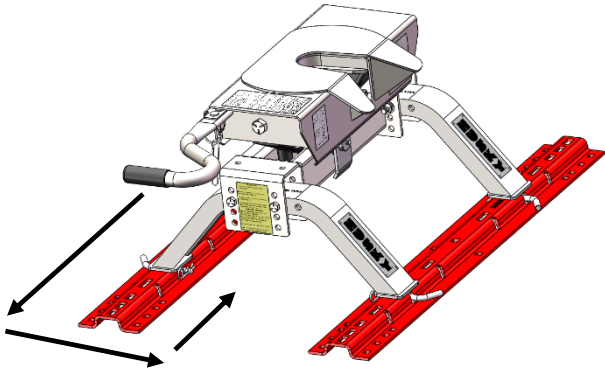

6. Check that the lock hasp indicator shows jaw open.
7. Slowly drive the truck out from underneath of the trailer.
8. **Observe the lock hasp to ensure the hitch does not accidentally close during uncoupling.**



WARNING

DURING COUPLING AND UNCOUPLING OF THE TRAILER SUDDEN AND UNEXPECTED MOVEMENTS OF THE TRUCK AND/OR TRAILER MAY OCCUR. ALWAYS KEEP WELL CLEAR OF THE TRUCK AND TRAILER DURING COUPLING AND UNCOUPLING.

OPERATIONS SUCH AS CONNECTING AND DISCONNECTING POWER CABLES, OPENING AND CLOSING THE HITCH, INSTALLING SAFETY CLIPS OR PADLOCKS SHOULD ONLY BE UNDERTAKEN WHEN THE WEIGHT OF THE TRAILER IS BEING CARRIED ON THE TRAILER LANDING GEAR, THE WHEELS OF THE TRAILER ARE CHOCKED AND THE TRUCK IS IN PARK WITH THE EMERGENCY BRAKE APPLIED.

Maintenance

1. Inspect the hitch each time before connecting a trailer, check to ensure all fasteners are tight and there are no cracks or excessive wear on the hitch; and also make sure that the jaw mechanism moves freely. Check that King Pin Indicator in the hitch is working correctly by pulling the handle out, then while holding the handle forward letting it slide back into the hitch. The Jaw should not close all the way. **If the Jaw closes all the way with no King Pin in place then the hitch is defective and must be repaired or replaced.** If excessive wear or damage is found, contact your installing dealer or HUSKY technical support staff at www.huskytow.com or 1-877-544-4449
2. After the first 100 miles, and at least once a year thereafter, inspect all bolts for proper tightness. Retighten nuts if needed. All fasteners ½" diameter, torque to 75 ft.-lbs.
3. Apply bearing grease to top plate before coupling, or use a lubrication plate min diameter 10", max thickness 3/16" (See Husky Dealer).

Lubrication.

1. The moving parts of the hitch require regular lubrication. (Every 3 to 6 month). Particular attention should be paid to the Slide Arm, Cam Track, Jaw Pivot and Indicator Mechanism. (As shown in the sketch)

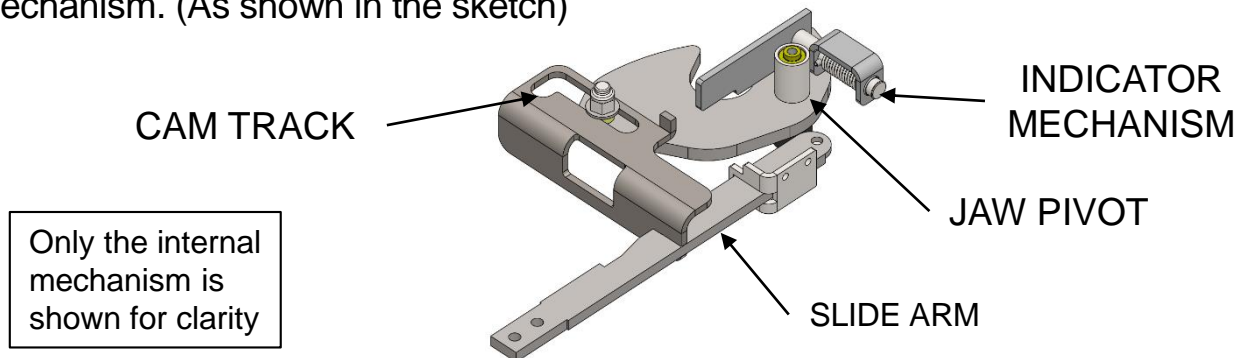

2. For best use apply a White Lithium Grease liberally to all moving surfaces including Pivot Pin holding the Head and Yoke to the Cross Beam. To ensure thorough lubrication, take the Head and Yoke off the Cross Beam by removing the Pivot Pin and turn the Head and Yoke upside down beam to gain access to the underneath of the Hitch. Pull the handle to access the parts easily. It is not recommended that the Hitch be disassembled any further than removing the Pivot Pin. It should be noted the bolts holding the Head to the Yoke are tightened to 240 ft.-lbs. of torque. Reassemble the Hitch taking care to replace the Safety Lock Pin in the Castle Nut of the Pivot Pin.
3. Alternatively the Hitch mechanism may be liberally sprayed with "Spray White Lithium Grease" (Obtainable in Auto Part Stores) every couple of months. Note warnings on Spray Can.
4. **Caution: The latch mechanism can close with heavy force. Use extreme care to keep fingers, hands, extremities & clothing out of the path of the mechanism. Failure to do so could result in severe injury.**
5. Grease the Zerk fitting periodically, located on plate side of pivot pin.

Towing Tips

Driving Tow Vehicle

Good habits for normal driving need extra emphasis when towing a trailer. The additional weight of the trailer affects acceleration and braking. Extra time should be allowed for passing, stopping and changing lanes. Signal well in advance of a maneuver to let other drivers know your intentions. Severe bumps and badly undulating roads can damage your towing vehicle, hitch and trailer, and should be negotiated at a slow, steady speed. If any part of your towing system “bottoms out” or if you suspect damage may have occurred in any other way, pull over and make a thorough inspection. Correct any problems before resuming travel.

Turning and backing up present new problems; plan ahead.

Towing a trailer will change your turning radius, the longer the trailer the larger radius turn.

Driving Conditions

When driving in conditions where the pavement is wet, icy, snowy, loose gravel, grass and dirt, reduce speed and do not make any sudden maneuvers. Allow ample distance/time for stopping and changing lanes. If possible, wait for road conditions to improve before driving.

Follow all state, local and provincial driving and towing laws in the location you are driving in.

Not following your tow vehicle, trailer, and Husky instructions/manuals can result in a fatal accident.

Check Your Equipment

Please refer to the MAINTENANCE section. Periodically check the condition of all your towing equipment and keep it in top condition.

Trailer Loading

Proper trailer loading is very important. Heavy items should be placed close to the floor near the trailer axle centerline. The load should be balanced side to side and firmly secured in the trailer to prevent shifting.

Tire Inflation

Unless specified otherwise by the towing vehicle or trailer manufacturer, tires should be inflated to their manufacturer’s towing recommendations.

Towing Vehicle And Trailer Manufacturers Recommendations

Review the owner’s manual for your towing vehicle and trailer for specific recommendations, capacities and requirements and do not exceed them.

Passengers in Trailers

Husky Towing does not recommend passengers traveling in or on trailers during towing.

Trailer Lights, Turn Signals, Electric Brakes

Always hook up all of the trailer lights, electric brakes and break-away switch connection whenever trailer is being towed. Also periodically check functionality of all lights before towing and repair any problems as needed.

Trouble Shooting

Problem	What To Look For	Solution
Hitch is difficult to install and remove from the base rails.	Hitch is not assembled correctly.	Refer to Hitch Assembly section for proper assembly instructions.
	Base Rails are not parallel with each other.	Use spacer to hold both base rails parallel while loosening and retightening the carriage bolts.
	Truck bed collapsing around carriage bolts in base rails.	Install proper spacers between the base rail and corrugations. Refer to installation instructions for specific directions.
Hitch will not hook up to the trailer king pin.	Incorrect king pin height	The king pin plate should be ½” to 1” below the 5 th wheel skid plate.
	Excessive angle between hitch head and king pin.	Level trailer or tow vehicle with blocks under the wheels.
	Lube disc is too thick.	Check thickness of lube disc. It should not exceed 3/16”.
	Bent king pin.	Contact your local dealer for replacement.
Hitch is difficult to unhook from trailer.	King pin is resting against the latch, preventing it from sliding open.	Remove pressure on the latch by blocking the trailer wheels in front and behind. With trailer wheels blocked and truck running, place truck in reverse, set the parking brake and then put truck in park and turn off the engine. This should relieve the pressure on the latch.
	Incorrect king pin height.	Trailer is up to high; retract the trailer landing legs to remove tension from slide bar.
	Excessive angle between hitch head and king pin.	Level trailer or tow vehicle with blocks under the wheels.
	Lube disc is too thick.	Check thickness of lube disc. It should not exceed 3/16”.
	Bent king pin.	Contact your local dealer for replacement.
Latch is difficult to close or open.	Damaged hitch head.	Contact your local dealer for replacement.
	Lack of lubrication.	Lubricate latch mechanism and pivot with a light coating of grease on all contact surfaces.
Latch does not lock into the open position.	Missing spring on trip mechanism.	Contact technical support for replacement spring.
	Missing or damaged trip mechanism.	Inspect trip mechanism. The trip mechanism should not be bent and the spring should be attached and have good tension.
Table top distorted/cracking at	Wear and tear.	Replace hitch head, contact technical support

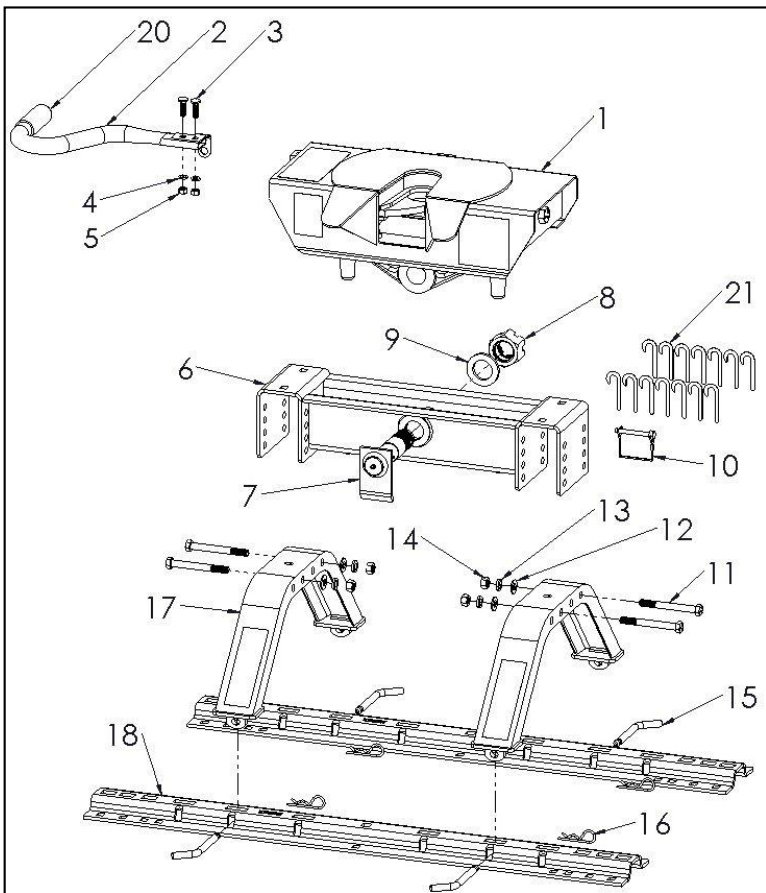

16K W Fifth Wheel Hitch Parts		33158 BOX 1		31587 BOX 2		31314		31573		31574		31575		31576		31580		31581		31579		31703		32043	
		QTY	QTY	QTY	QTY	QTY	QTY	QTY	QTY	QTY	QTY	QTY	QTY	QTY	QTY	QTY	QTY	QTY	QTY	QTY	QTY	QTY	QTY	QTY	QTY
1	16K 5TH WHEEL HEAD ASSEMBLY	1	-	-	-	-	-	-	-	-	-	-	-	-	-	1	-	-	-	-	-	-	-	-	-
2	HANDLE	1	-	-	1	-	-	-	-	-	-	-	-	-	-	-	-	-	-	-	-	-	-	-	-
3	CARRIAGE BOLT, 3/8-16 X 1.25" LONG	2	-	-	2	-	-	-	-	-	-	-	-	-	-	-	-	-	-	-	-	-	-	-	-
4	LOCK WASHER, 3/8" ID	2	-	-	2	-	-	-	-	-	-	-	-	-	-	-	-	-	-	-	-	-	-	-	-
5	HEX NUT, 3/8-16	2	-	-	2	-	-	-	-	-	-	-	-	-	-	-	-	-	-	-	-	-	-	-	-
N/A	INSTRUCTIONS 16K (NOT SHOWN)	1	1	-	1	1	1	1	1	1	1	1	1	1	1	1	1	1	-	-	-	-	1	-	-
6	CROSS MEMBER	-	1	-	-	-	-	-	-	-	-	-	-	1	-	-	-	-	-	-	-	-	-	-	-
7	PIVOT PIN	-	1	-	-	1	-	-	-	-	-	-	-	-	-	-	-	-	-	-	-	-	-	-	-
8	CASTLE NUT, 1-1/2-12	-	1	-	-	1	-	-	-	-	-	-	-	-	-	-	-	-	-	-	-	-	-	-	-
9	CASTLE NUT SPACER WASHER	-	1	-	-	1	-	-	-	-	-	-	-	-	-	-	-	-	-	-	-	-	-	-	-
10	SAFETY LOCKING PIN	-	1	-	-	1	-	-	-	-	-	-	-	-	-	-	-	-	-	-	-	-	-	-	-
11	HEX HEAD BOLT, 1/2-13 X 4.5" LONG	-	4	-	-	-	4	-	-	-	-	-	-	-	-	-	-	-	-	-	-	-	-	-	-
12	WASHER, 1/2"	-	4	-	-	-	4	-	-	-	-	-	-	-	-	-	-	-	-	-	-	-	-	-	-
13	LOCK WASHER, 1/2"	-	4	-	-	-	4	-	-	-	-	-	-	-	-	-	-	-	-	-	-	-	-	-	-
14	HEX NUT, 1/2-13 UNC	-	4	-	-	-	4	-	-	-	-	-	-	-	-	-	-	-	-	-	-	-	-	-	-
15	1/2" BASE RAIL PIN	-	4	-	-	-	-	4	-	-	-	-	-	-	-	-	-	-	-	-	-	-	-	-	-
16	HAIR PIN	-	4	-	-	-	-	4	-	-	-	-	-	-	-	-	-	-	-	-	-	-	-	-	-
17	UPRIGHT	-	-	2	-	-	-	-	-	-	-	-	-	-	-	-	-	-	-	-	-	-	-	-	-
18	BASE RAIL FOR 5TH WHEEL (NOT INCLUDED)	NA	NA	NA	NA	NA	NA	NA	NA	NA	NA	NA	NA	NA	NA	NA	NA	NA	NA	NA	NA	NA	NA	NA	NA
19	RUBBER BUMPER		2	-	-	-	-	-	-	-	-	-	2	-	-	-	-	-	-	-	2	-	-	-	-
20	FOAM GRIP HANDLE	1	-	-	1	-	-	-	-	-	-	-	-	-	-	-	-	-	2	-	-	-	-	-	-
21	SHIM KIT	-	-	14	-	-	-	-	-	-	-	-	-	-	-	-	-	-	-	-	-	-	-	14	-

Appendix A

Weighing Truck and 5th Wheel Trailer.

Weigh the Truck and 5th Wheel on a public weigh scale. Public weigh scales can be found at Some Truck Stops, or they can be located from Yellow pages or on the Internet.

Weigh the Truck and 5th Wheel in 3 stages as shown in the sketch.



Step 1, Weigh the both the Truck and 5th Wheel. This is **weight 1**; this will give the **GCW (Gross Combination Weight)** of the Truck and 5th Wheel Trailer. The **GCW** must not exceed the **GCWR (Gross Combination Weight Rating)** for the Truck. The **GCWR** of a truck depends on engine size, transmission, rear axle ratio, tow package and other factors. The manufacturer or dealer will be able to find the **GCWR** from the **VIN (Vehicle Identification Number)** of the truck.

Step 2, Drive the front wheels of the truck off the weighing platform. Weigh the rear wheels of the truck and the 5th Wheel Trailer wheels. This is **weight 2**, Subtract **weight 2** from the **weight 1**; the result is the **GAW (Gross Axle Weight)** for the front axle of the truck. The **GAWR (Gross Axle Weight Rating)** for the front axle can be found on the **VIN** plate on the driver's side door pillar, the measured front **GAW** must not exceed the front **GAWR** on the **VIN** plate.

Step 3, Drive the rear wheels of the truck off the weighing platform; this should leave only 5th Wheel Axles remaining on the weighing platform. This is **weight 3**, Subtract **weight 3** from the **weight 1** and this is the **GVW (Gross Vehicle Weight)** of the truck. The measured **GVW** must not exceed the **GVWR** found on the **VIN** plate. Subtract **weight 3** from **weight 2** and this is the measured **GAW** of the rear axle of the truck, and must not exceed the **GAWR** of the rear axle found on the **VIN** plate. **Weight 3** is also the **GAW** of the 5th Wheel; this weight should not exceed the **GAWR** on the plate on the 5th Wheel.

Summary:

GCW (Truck & 5th Wheel Trailer) = Weight 1
GAW (Front axle of truck) = Weight 1 - Weight 2
GVW (Truck) = Weight 1 - Weight 3
GAW (Rear axle of truck) = Weight 2 – Weight 3
GAW (Axles of 5th wheel trailer) = Weight 3

WARNING! EXCEEDING ANY WEIGHT RATING IS HAZARDOUS. OVERLOADING OF TRUCK AND/OR 5TH WHEEL TRAILER CAN LEAD TO TIRE FAILURE, BRAKE FADE, & OVERHEATING OF THE TRUCK ENGINE OR TRANSMISSION. OVERLOADED VEHICLES ARE MORE UNSTABLE AND UNPREDICTABLE IN NORMAL DRIVING CONDITIONS.

Warranty Terms:

5 Year Limited Warranty:

This warranty applies solely to Husky 5th Wheel Hitch manufactured by Keystone Automotive Operations Inc. for Husky Towing Products.

Husky Towing Products and Keystone Automotive Operations Inc. make no guarantees or warranties for products not manufactured by Keystone Automotive Operations Inc. Such products are covered solely under any applicable warranty of the manufacturer. It is always recommended that the operating instructions and warranty instructions provided by the manufacturer are followed.

Keystone Automotive Operations Inc. warrants its products to be free from manufacturing and material defects to the original purchaser for the length of warranty stated above from the date of retail purchase. If any products are found to have a manufacturing or material defect, the product will be replaced or repaired at the option of Husky Towing Products and Keystone Automotive Operations Inc. with proof of purchase by the original purchaser. The original purchaser shall pay all transportation and shipping costs associated with the return of the defective product and the defective product shall become the property of Keystone Automotive Operations Inc.

The Warranty applies to Keystone Automotive Operations Inc. products used for individual and recreational purposes. Commercial usage of the Keystone Automotive Operations Inc. products limits the warranty to 90-days from date of purchase.

The Warranty applies only to Keystone Automotive Operations Inc. products which are found to be defective in manufacturing or material. This warranty does not apply to normal wear and tear of the finish placed on Keystone Automotive Operations Inc. products.

Husky Towing Products and Keystone Automotive Operations Inc. are not responsible for any labor costs incurred for removal or replacement of the defective product.

Husky Towing Products and Keystone Automotive Operations Inc. are not responsible for repair or replacement of any product under the limited warranty where the product was improperly installed, misapplied, altered, abused, neglected, overloaded, misused or damaged as a result of an accident, including any use of the product not in accordance with all product operating and safety instructions.

Without limiting the generality of the foregoing, Husky Towing Products and Keystone Automotive Operations Inc. shall under no circumstances be liable for any incidental or consequential loss or damage whatsoever arising out of, or in any way relating to any such breach of warranty or claimed defect in, or non-performance of the products. Some states do not allow the exclusion or limitation of incidental or consequential damages, so the above exclusion or limitation may not apply to you.

This limited warranty gives you specific legal rights, and you may also have other rights that vary from state to state.